



Professional H.264 HD Encoder Module

DMM-1520EC

User Manual

<http://www.pbi-china.com>

Contents

Notices.....	1
1 Overview.....	3
2 Features.....	3
3 Technical Specifications	3
4 Order Information.....	4
5 Block Diagram.....	5
6 Front panel and rear panel instructions.....	6
6.1 Front panel	6
6.2 Rear panel.....	7
7 Menu Structure	8
8 Menu Operating Instructions via DMM-1000CU.....	10
8.1 Status	10
8.2 Encoder Setup.....	11
8.3 IP Board Setup	13
8.4 PID Processing.....	14
8.5 Output Setup	16
8.6 Syetem	16
9 Web Control.....	17
9.1 Status	17
9.2 Encoder.....	17
9.3 TS over IP	18
9.4 Output.....	20
9.5 MUX	20
9.6 System	21

Notices

COPYRIGHT (Copyright © 2012 Beijing Jaeger Communication Electronic Technology Co., Ltd.)

Not to be copied, used or translated in part or whole without Beijing Jaeger prior consent in writing except approval of ownership of copyright and copyright law.

WARRANTY

This warranty does not cover parts which may become defective due to misuse of the information contained in this manual.

Read this manual carefully and make sure you understand the instructions provided. For your safety, be aware of the following precautions.



WARNING! IMPORTANT SAFETY INSTRUCTIONS

CAUTION: TO REDUCE THE RISK OF ELECTRIC SHOCK, DO NOT REMOVE COVER (OR BACK). NO USER SERVICEABLE PARTS INSIDE. REFER SERVICING TO QUALIFIED SERVICE PERSONNEL.

WARNING

- To reduce the risk of fire or electric shock, do not expose this apparatus to rain or moisture.
- To avoid explosion danger, do not dispose of batteries in an open fire.

CE MARK FOR EUROPEAN HARMONISED STANDARDS



The CE mark which is attached to these products means it conforms to EMC Directive (89/336/EEC) and Low Voltage Directive (73/23/EEC).

IMPORTANT INFORMATION

Please retain the original packaging, should it be necessary at some stage to return the unit.

Disposal of Old Electrical and Electronic Equipment (Applicable in the European Union and other European countries with separate collection systems)



This symbol on the product or on its packaging indicates that this product shall not be treated as household waste. Instead it shall be handed over to the applicable collection point for the recycling of electrical and electronic equipment. By ensuring this product is disposed of correctly, you will help prevent potential negative consequences for the environment and human health, which could otherwise be caused by inappropriate waste handling of this product. The recycling of materials will help to conserve natural resources. For more detailed information about recycling of this product, please contact your local Civic Office, your household waste disposal service, or the shop where you purchased the product.

COPYRIGHTS

Television programs, movies, video tapes, discs, and other materials may be copyrighted. Unauthorized recording of copyrighted material may be against the copyright laws in your region. Also, use of this product with cable television transmissions may require authorization from the cable television operator or transmitter/owner.

VENTILATION

- Do not expose the product to high temperatures, such as placing it on top of other product that produce heat or in places exposed to direct sunlight or spot lights.
- The ventilation slots on top of the product must be left uncovered to allow proper airflow into the unit.
- Do not stand the product on soft furnishings or carpets.
- Do not stack electronic equipment on top of the product.
- Do not place the product in a location subject to extreme changes in temperature. The temperature gradient should be less than 10 degrees C/hour.
- Place the product in a location with adequate ventilation to prevent the build-up of heat inside the product. The minimum ventilation space around the unit should be 7 cm. The ventilation should not be impeded by covering the ventilation openings with items, such as newspapers, table cloth, curtains, etc.

POWER SOURCES



ООО «ТЛК Трейд», Санкт-Петербург

+7 812 64 99 888

mail@tlct.ru

- The product is not disconnected from the AC power source (mains) as long as it is connected to the power outlet or wall socket, even if the product is turned off.
- If the product will not be used for a long period of time, disconnect it from the AC power outlet or wall socket.

Before Using the Device

Thank you for purchasing DMM-1520EC H.264 HD encoder module. This User Manual is written for operators/users of the DMM-1520EC to assist in installation and operation. Please read this user manual carefully before installation and use of the device.

FOR YOUR SAFETY

This equipment is provided with a protective earthing ground incorporated in the power cord. The main plug shall only be inserted in a socket outlet provided with a protective earth contact. Any interruption of the protective conductor, inside or outside the device, is likely to make the device dangerous. Do not remove the covers of this equipment. Hazardous voltages are present within this equipment and may be exposed if the covers are removed. Only Beijing Jaeger trained and approved service engineers are permitted to service this equipment.

The supplied AC power cable must be used to power the device. If the power cord becomes damaged it must be replaced. No operator serviceable parts inside. Refer servicing to Beijing Jaeger trained and approved service engineers. For the correct and safe use of the device, it is essential that both operating and servicing personnel follow generally accepted safety procedures in addition to the safety precautions specified in this manual. Whenever it is likely that safety protection is impaired, the device must be made in-operative and secured against unintended operation. The appropriate servicing authority must be informed. For example, safety is likely to be impaired if the device fails to perform the intended measurements or shows visible damage.

WARNINGS

- The mounting environment should be relatively dust free, free of excessive vibration and the ambient temperature between 0C° to 40C°. Relative humidity of 20% to 80% (non-condensed) is recommended.
- Avoid direct contact with water.
- Never place the equipment in direct sunlight.
- The outside of the equipment may be cleaned using a lightly dampened cloth. Do not use any cleaning liquids containing alcohol, methylated spirit or ammonia etc.
- For continued protection against fire hazard, replace line fused only with same type.
- Air intake for cooling is achieved via holes at the side of the device and the fans inside. The air flow should not be obstructed. Therefore, the device has to be placed on a flat surface, leaving some space at the sides of the device.
- When in operation, the internal temperature should not exceed the limit of 70C°.

DMM-1520EC

Professional H.264 HD Encoder Module

1. Overview

DMM-1520EC is a highly adaptable single channel H.264 (MPEG-4 AVC) HD Encoder, which provide users a high-level operation experience to meet the requirement of the Digital broadcasting market. The DMM-1520EC support various input interface that include HD/SD-SDI, HD/SD-HDMI and CVBS. The compressed stream could output via GbE IP and ASI. DMM-1520EC can encode two pairs of stereo audio with its 2nd audio daughter board. With built-in re-multiplexer, DMM-1520EC could re-multiplex the SPTS generated itself and a MPTS input from ASI or IP, which makes DMM-1520EC the most suitable deployment choice for any broadcast system.

2. Features

- ⊙ Fully compliant with H.264 HP@Level 4.0 and MP@Level 3.0
- ⊙ Multiple video resolution including 1080i, 720p, 576i and 480i
- ⊙ Multiple inputs HD/SD-HDMI, HD/SD-SDI, and CVBS for encoding
- ⊙ Support GbE TS/IP input/output(full duplex)
- ⊙ Built-in Re-mux can multiplex services from ASI Input, IP input with encoded service.
- ⊙ Support PSI/SI edition.
- ⊙ Support VBR and CBR encoding mode
- ⊙ Support 2 pairs of analog stereo audio encoding with optional extension audio board
- ⊙ Remote Control and Supervision by SNMP, HTTP WEB
- ⊙ Support Down scale without changing frame rate.

3. Technical Specifications

Video Input & Compression	
Video Input	1 x HD/SD-HDMI(v1.3) 1 x BNC for CVBS input 1 x BNC for HD/SD-SDI input(for DMM-1520-3x and DMM-1520-4x model only)
Compression Standard	H.264/AVC HP@L4.0
Chrominance Space	4:2:0
Video Encoding Bit Rate	2Mbps~30Mbps



Video Resolutions & Recommended Video Encoding Bit Rates	1080i (1920x1080) @25Hz,29.97Hz,30Hz: SMPTE274M: 6~24Mb/s 1080i (1440x1080) @25Hz,29.97Hz,30Hz: SMPTE274M: 5~24Mb/s 720p (1280x720) @50Hz,59.94Hz,60Hz: SMPTE296M: 4~24Mb/s 480i (720x480) @29.97Hz: SMPTE656M: 2~10Mb/s 576i (720x576) @25Hz: SMPTE656M: 2~10Mb/s
Audio Input & Compression	
Audio Input	HDMI Embedded Analog L,R audio input via a 2.5mm phone jack SDI Embedded(for DMM-1520-3x and DMM-1520-4x model only) 2 nd analog L,R audio input via an extension audio board(for DMM-1520-x2 model only)
Compression Standard	MPEG1 Layer II Encoding (Mono, Stereo)
	MPEG2 AAC-LC Encoding (Stereo)
	MPEG4 AAC-LC Encoding (Stereo)
Sampling Rate	48KHz
Audio Compression Bit Rate	MPEG1 Layer II: 32~256Kb/s (Both 2 pairs of audio on DMM-1520EC-x2 model) AAC-LC: 128~512Kb/s (1 st pair of audio only)
DVB-ASI Input	
Connector Type	1 x BNC Female, 75Ω
Maximal Input Bit Rate	100 Mb/s
Packet Mode	Byte
Packet Length	188/204 Bytes
Signal Level	200 ~ 880mVp-p
DVB-ASI Output	
Connector Type	1 x BNC Female, 75Ω
Effectual Output Bit Rate	1.5 Mb/s ~ 70 Mb/s
Packet Mode	Byte
Packet Length	188/204 Bytes
Signal Level	800±80mV
GigE Full Duplex	
GbE Full Duplex	IEEE 802.3, 10/100/1000 Base-T
Maximal Effectual Output Bit Rate	80Mb/s

UDP/RTP	SPTS or MPTS
Protocol	IGMPv2
Control&Monitoring	
Connector Type	1xRJ45, 10/100 Base-T, for equipment Control
Remote Control	SNMP, HTTP(WEB interface)
Local Control	Handheld Programmer Unit
Software Upgrade	FTP loader and Telnet
Physical parameter	
Power supply	DC 3.3V/5V/12V, supplied by DMM-1000MF chassis
Power Consumption	<18W
Dimension	380mm x 111.5mm x 33mm
Weight	1.0kg
Operating Temperature	0 ~ 45°C
Storage Temperature	-10 ~ 60°C
Humidity	10 ~ 90%, Non-condensed

4. Order Information

Function \ Model		DMM-1520EC-XX							
		-10	-12	-20	-22	-30	-32	-40	-42
Input	HDMI	•	•	•	•	•	•	•	•
	CVBS	•	•	•	•	•	•	•	•
	Audio 1	•	•	•	•	•	•	•	•
	Audio 2		•		•		•		•
	SDI					•	•	•	•
	ASI	•	•	•	•	•	•	•	•
Output	ASI x2	•	•	•	•	•	•	•	•
TS/IP GbE				•	•			•	•

5. Block Diagram

1520EC Function Block Diagram

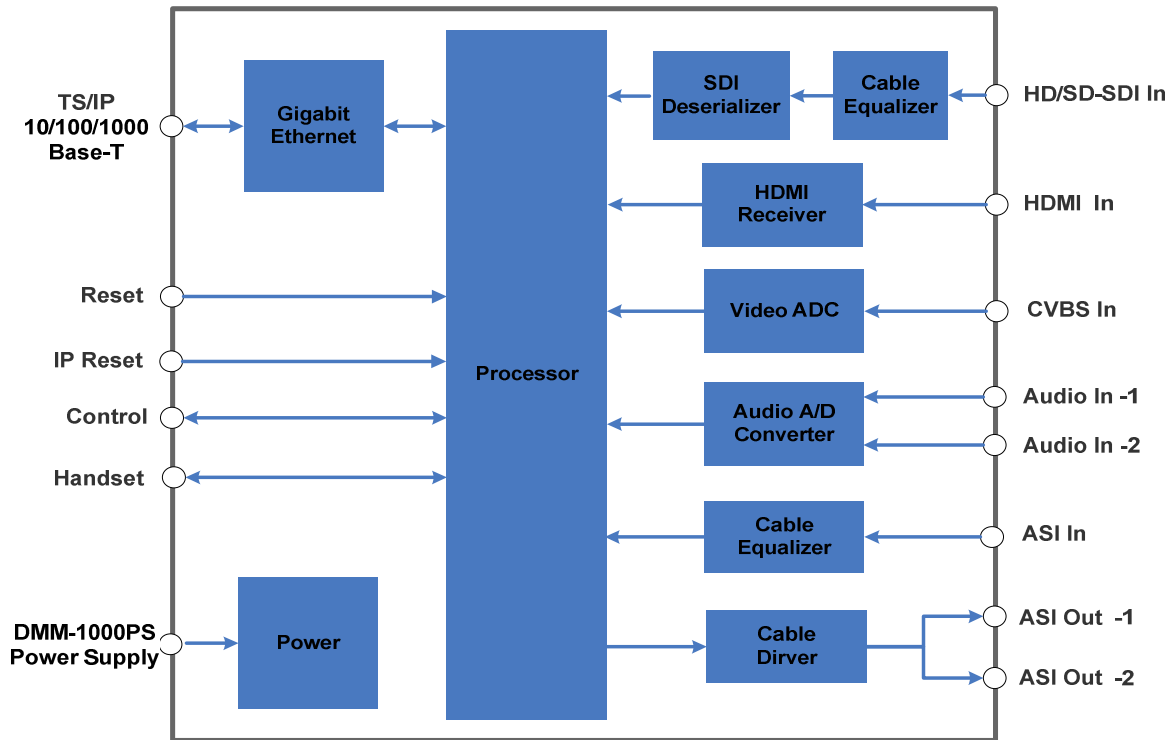

6. Front panel and rear panel instructions

6.1 Front panel

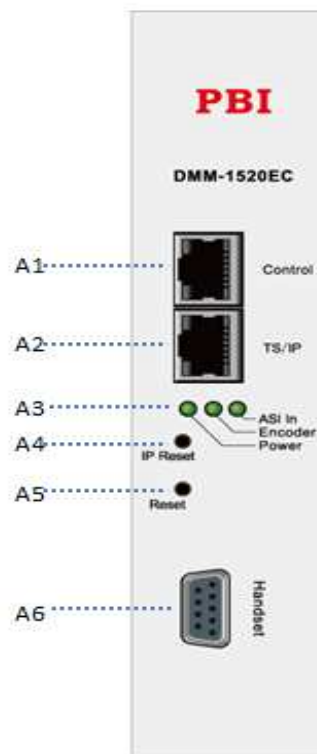

A1 Control	Network management interface for remote control
A2 TS/IP	TS/IP input/output interface
A3 Indicator	Three indicators for Power, Encoder, ASI In, green light on means power supply is working well
A4 IP Reset	Used to restore the IP address to default value
A5 Reset	Used to reboot the module
A6 Handset	Used to connect the DMM-1000CU for controlling the module.

6.2 Rear panel

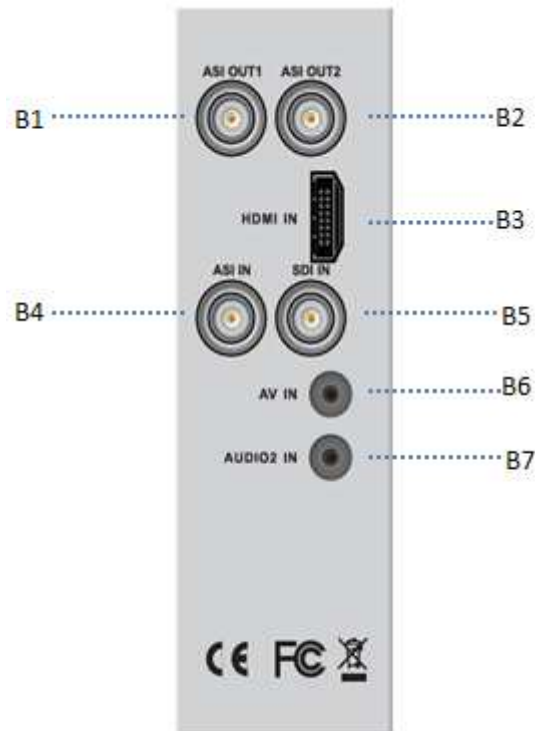

B1 ASI OUT1	ASI output interface1
B2 ASI OUT2	ASI output interface2
B3 HDMI IN	HDMI input interface
B4 ASI IN	ASI inout interface
B5 SDI IN	SDI input interface
B6 AV IN	Analog video input interface
B7 Audio2 IN	The second analog audio input interface

7. Menu Structure

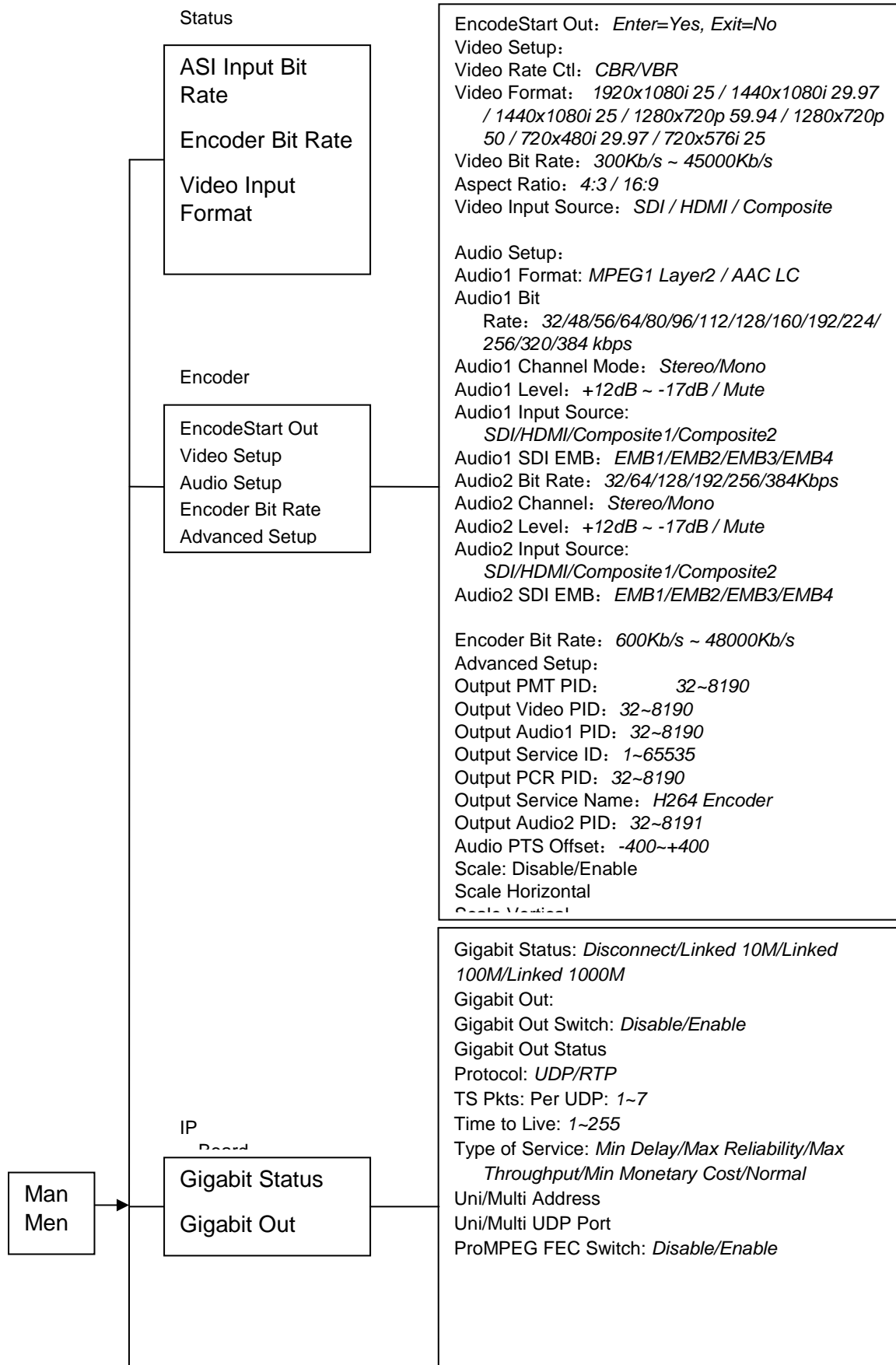



ООО «ТЛК Трейд», Санкт-Петербург
+7 812 64 99 888
mail@tlct.ru

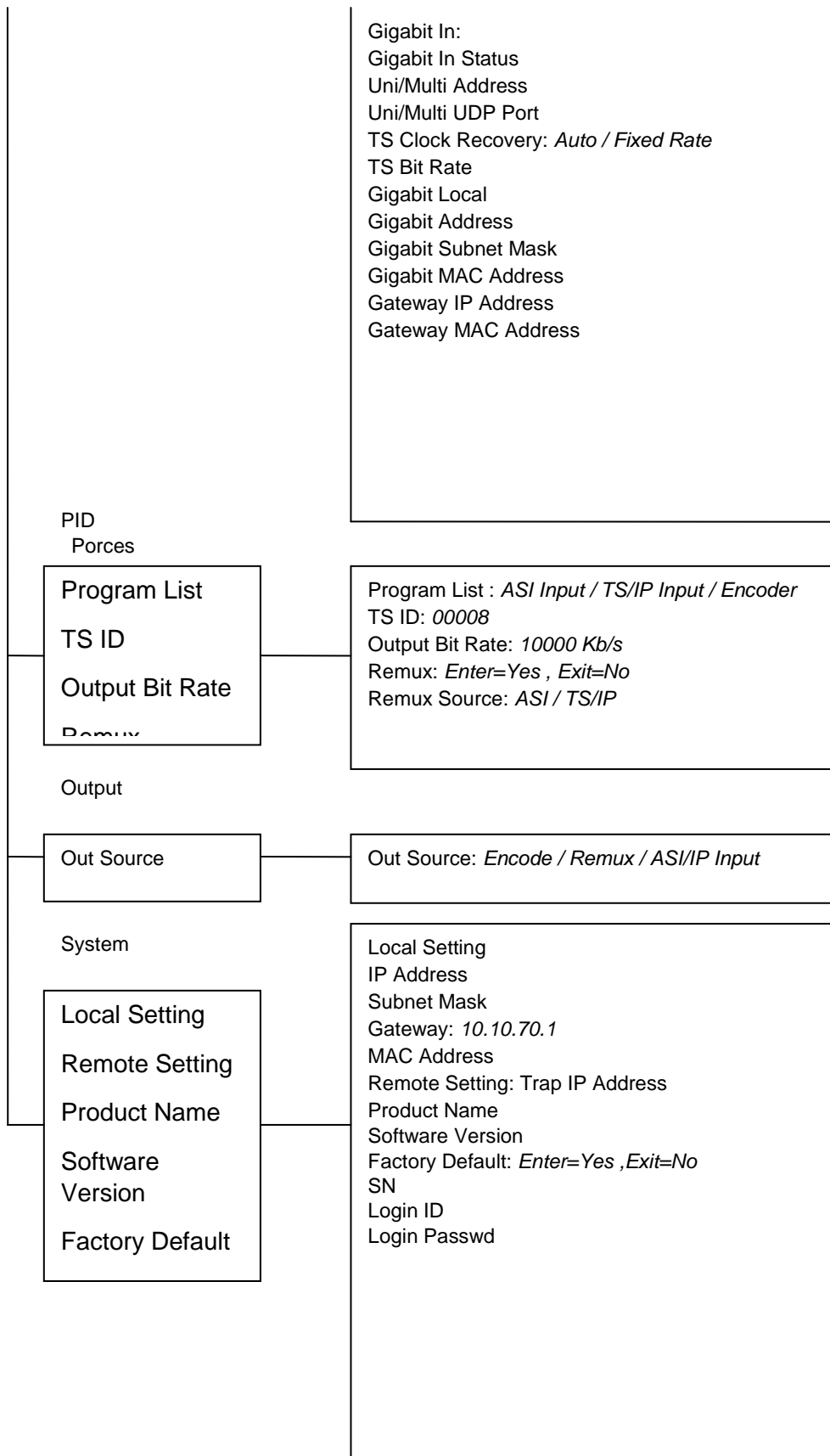

8. Menu Operating Instructions via DMM-1000CU

Users are advised to restore this device to factory settings before the first time using it. Because of machine's too many functions and the function of parameters collocation, users are advised not to change those parameters temporarily useless in order to avoid unnecessary fault.

After power on, the type of the product will be shown at the first row of LCD displayer, Local IP address will be shown at the second row. User can press [ENTER] to get into the main menu:

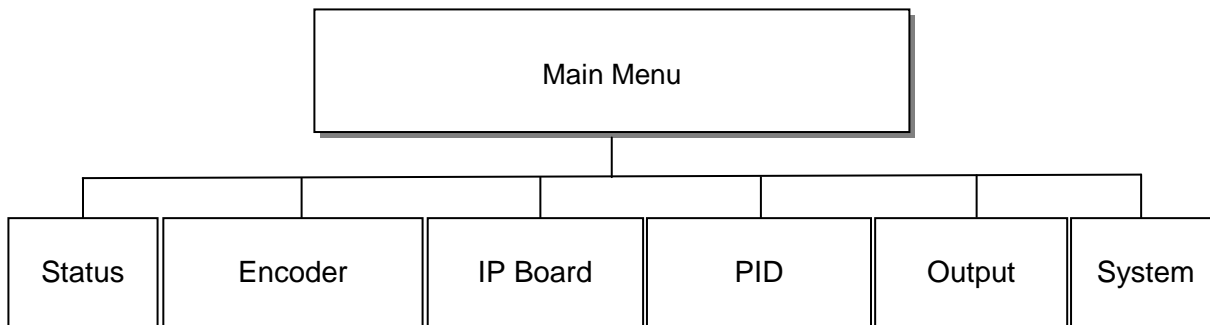

- (1) Status: Monitor status of the machine
- (2) Encode: Configure and monitor parameters of encoding procedure
- (3) IP Board: Configure and monitor parameters of IP Board
- (4) PID Processing: Configure and monitor parameters of TS re-multiplexing function
- (5) Output: Configure and monitor parameters of TS output
- (6) System: Configure and monitor system parameters

8.1 Status:

Here user can check status of input signal and encoder. It includes 3 options: ASI Input Bit Rate, Encoder Bit Rate, Video Input Format.

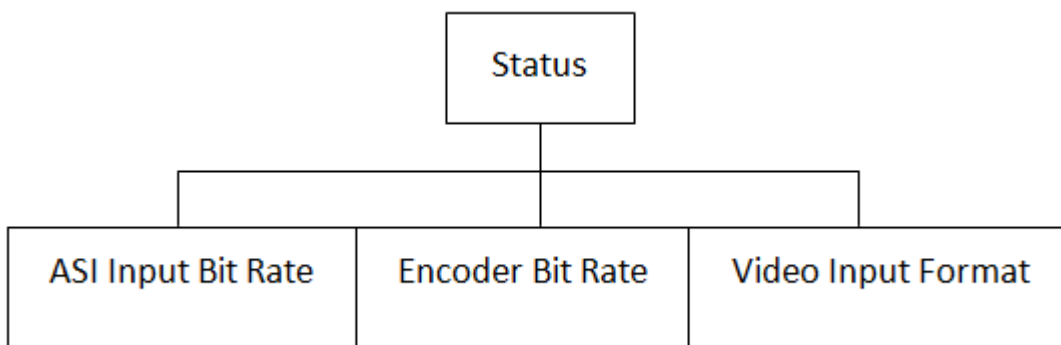

8.1.1 ASI Input Bit Rate

Here user can monitor the input signal bitrate of ASI interface.

8.1.2 Encoder Bit Rate

Here user can monitor the encoder bitrate.

8.1.3 Video Input Format

Here user can check the video format of input signal.

8.2 Encoder

Here user can configure and check all parameters of encoding function. It includes 5 sub-menus: Encoder Start Out, Video Setup, Audio Setup, Encoder Bit Rate, Advanced Setup.

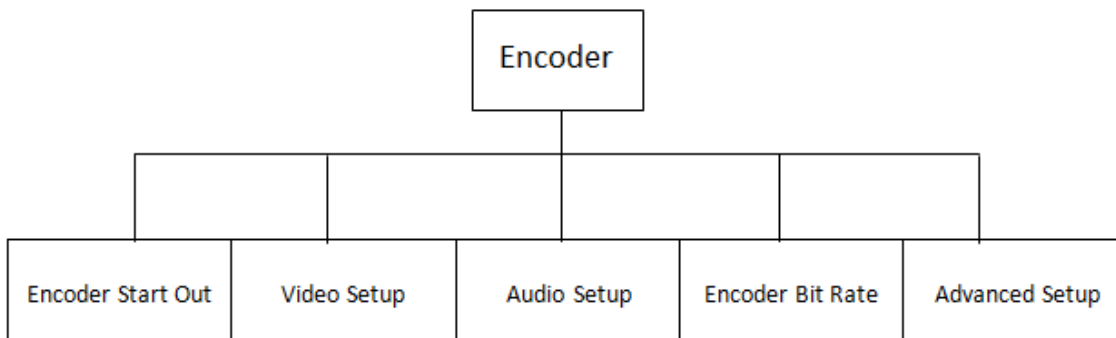

8.2.1 Encoder Start Out

Here users can operate the machine to start encoding after get all parameters ready.

EncodeStart Out: User can press "ENTER" to start encoding, or press "EXIT" to quit.

Attention: User has to reboot the machine after changing any parameters except those stressed with "Immediately valid". During the rebooting, if this line "...ERR, please check, wait" comes up on the LCD displayer, it means the new parameter is wrong, so please check out the wrong parameter. In addition, the line "Parameters changed, Enter=Save, Exit=No" will come up on LCD displayer while exiting the menu with any parameters changed, users have to push ENTER to save the new parameter.

8.2.2 Video Setup

Here user can check and configure parameters of video encoder.

- (1) Video Input Source: To configure the source of video signal, user can select among SDI, HDMI, Composite.
- (2) Video Format: To configure the video resolution for encoding, user can select among 1920*1080i 25fps; 1440*1080i 25, 29.97fps; 1280*720p 59.94, 50fps; 720*576i 25fps.
(Attention: the selected video format must be as same as the input video format).
- (3) Video Bit rate: To configure the encoding rate of video (Immediately valid).

(4) Video Rate Ctl: To configure the control type of TS rate, user can select between CBR(Constant Bit Rate) and VBR(Variable Bit Rate).

(5) Aspect Ratio: To configure the aspect ratio, user can select between 4x3 and 16x9.

8.2.3 Audio Setup

Here user can check and configure parameters of audio encoder. (Attention: Audio2's setting is valid only on 1520EC-12,1520EC-22,1520EC-32 and 1520EC-42)

- (1) Audio1 Format: To configure the encoding format of audio1, user can select between MPEG1 layer2 and AAC LC.
- (2) Audio1 Bit Rate: To configure the encoding bit rate of audio1. If the value of audio1 format is "MPEG1 layer2", the encoding bit rate of audio1 can be set among 32kbps, 48kbps, 56kbps, 64kbps, 80kbps, 96kbps, 112kbps, 128kbps, 160kbps, 92kbps, 224kbps, 256kbps, 320kbps, 384kbps. If the value of audio1 format is "AAC LC", the encoding bit rate of audio 1 can be set to any value from 128~512kbps.
- (3) Audio 1 Level: To configure the volume of audio1, its range is +12dB ~ -17dB. (Attention: positive means amplification, negative means reduction)
- (4) Audio 1 input Source: To configure the input source of audio1, user can select among SDI, HDMI, Composite1 and Composite2.
- (5) Audio 1 SID EMB: To configure the EMB num of SID, user can selected among EMB1, EMB2, EMB3 and EMB4.(Attention: These parameters are not valid unless the value of audio1 input source is "SDI Audio")

8.2.4 Encoder Bit Rate

Here user can configure and monitor the total encoding bit rate, it must be greater than the sum of audio and video bit rate.

Encoder Bit Rate: To configure the total encoding bit rate.

8.2.4 Advanced Setup

Here user can configure some parameters of PID, resolution scaling and other related information.

- (1) Output PMT PID: To configure the PMT PID number of transport stream, its range is 31~8191.
- (2) Output Video PID: To configure the Video PID number of output transport stream, its range is 31~8191.
- (3) Output Audio1 PID: To configure the Audio PID number of output transport stream, its range is 31~8191.

- (4) Output Service PID: To configure the Service PID number of output transport stream, its range is 0~65536.
- (5) Output PCR PID: To configure the Service PID number of output transport stream, its range is 31~8191.
- (6) Output Service Name: To configure the Service Name of output transport stream.
- (7) Output Audio2 PID: To configure the Audio PID number of output transport stream, its range is 31~8191.
- (8) Audio PTS Offset: To configure the synchronization between audio and video, user can press button “↑”, “↓”, “←”, “→” to adjust the synchronization, then press button “ENTER” to confirm the setting, its range is -400 ~ +400.
- (9) Scale: User can select Enable or Disable to open or close the function of video resolution scaling.
- (10) Scale Horizontal: To configure the width of video scaling, the default value is “720”. (Attention: User has to configure the value according to the actual need. It will cause an abnormal output bit rate after setting an unsuitable value, then user should close the scaling function and reboot the machine.)
- (11) Scale Vertical: To configure the height of video scaling, the default value is “720”. (Attention: User has to configure the value according to the actual need. It will cause an abnormal output bit rate after setting an unsuitable value, then user should close the scaling function and reboot the machine.)

8.3 IP Board Setup

Here user can configure and check all parameters of TS over IP. It includes 4 sub-menus: Gigabit In, Gigabit Out, Gigabit Local, Gigabit Status.

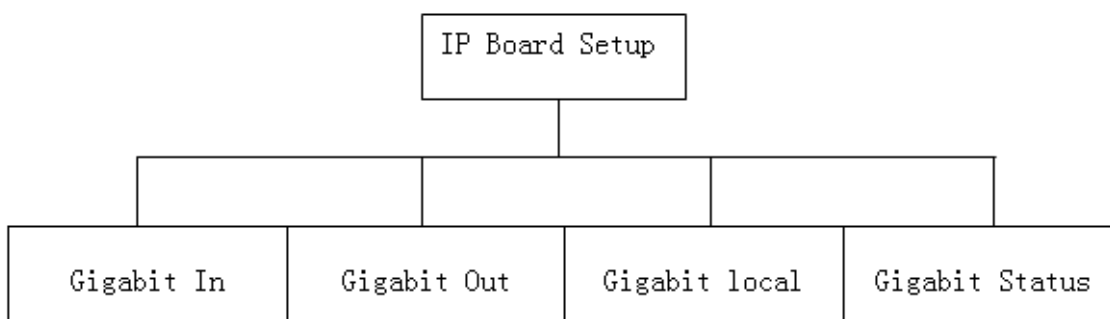

8.3.1 Gigabit In

Here user can check and configure parameters of TS over IP input.

- (1) Gigabit In Status: User can check reception status of gigabit port, including Gigabit In Status, Gigabit In Protocol, Column FEC, Row FEC, Pkts Per UDP Frames, Received TS Frames, Fixed RTP Frames and Total Lost Frames
- (2) Uni/Multi Address: To configure and check the IP address for unicast or multicast. IP address for unicast is 1.0.0.1~223.255.255.254, IP address for multicast is 224.0.0.0~239.255.255.255.
- (3) Uni/Multi UDP Port: To configure the port number of UDP input, its range is 0~65535.
- (4) Column FEC UDP Port: To configure the input port number of FEC UDP column, its range is 0~65535.
- (5) Row FEC UDP Port: To configure the input port number of FEC UDP row, its range is 0~65535.
- (6) TS Clock Recovery: To configure the recovery mode of TS Clock, user can select between Auto and Fixed Rate.

8.3.2 Gigabit Out

Here user can check and configure parameters of TS over IP output.

- (1) Gigabit Out Switch: User can select Enable or Disable to open or close the TS/IP output function of the gigabit port
- (2) Gigabit Out Status: User can check the output status of the gigabit port, including UDP Packets/s, Column FEC pkts/s and Row FEC pkts/s.
- (3) Protocol: To configure the protocol of TS/IP output, user can select between UDP and RTP.
- (4) TS Pkts Per UDP: To configure the quantity of TS/IP packet under UDP standard, user can select among 1, 2, 3, 4, 5, 6 and 7.
- (5) Time To Live: To configure the maximum quantity of router which TS/IP can reaches. Its range is from 1 to 255. (Attention: If a TS/IP packet has already passed through those routers up to maximum quantity, but still does not arrival the destination, it will be abandoned.)
- (6) Type Of Service: To configure the service type, user can select among Min Delay, Max Reliability, Max Throughput and Normal.
- (7) Uni/Multi Address: To configure the IP address of TS/IP unicast or multicast, IP range for unicast is 1.0.0.1~223.255.255.254. IP range for multicast is 224.0.0.0~239.255.255.255.
- (8) Uni/Multi UDP Port: To configure the port number of UDP output, its range is 0~65535.
- (9) ProMPEG FEC Switch: User can select Enable or Disable to open or close the function of FEC(Forward Error Correction).

8.3.3 Gigabit Local

Here user can configure local parameters of TS/IP board.

- (1) Gigabit Address: To configure the physical IP address of TS/IP board.
- (2) Gigabit Subnet Mask: To configure the subnet mask of TS/IP board.
- (3) Gigabit MAC Address: To check the MAC address of TS/IP board.

- (4) Gateway IP Address: To configure the gateway address of TS/IP board.
- (5) Gateway MAC Address: To configure the MAC address of target gateway. The default value is ff.ff.ff.ff.ff.

8.3.4 Gigabit Status

Here user can check the current status of network connection.

- (1) Disconnect: There is no network connecting to this machine.
- (2) Linked 10M: There is a 10M network connecting to this machine.
- (3) Linked 100M: There is a 100M network connecting to this machine.
- (4) Linked 1000M: There is a 1000M network connection to this machine.

8.4 PID Processing

Here user can configure and check parameters related to multiplex function. It includes 5 sub-menus: Program List, TS ID, Output Bit Rate, MUX, MUX Source.

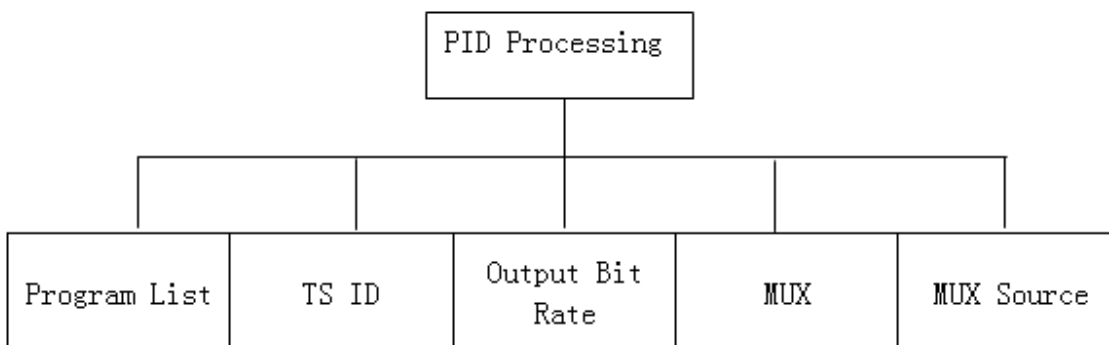

8.3.1 Program List

Here user can check all programs from ASI input and Encoder. Users can also choose programs they want to be re-multiplexed.

- (1) ASI Input: To choose programs which user wants to be re-multiplexed. those programs from ASI input will be listed, user can push button “ENTER” to mark the programs with a symbol “*”, all the programs marked with “*” will be re-multiplexed. (Attention: Programs from IP input will be listed while the TS/IP board is working under input status)
- (2) Encoder: To choose programs which user wants to be re-multiplexed. Those programs from encoder itself will be listed, user can push button “ENTER” to mark the programs with a symbol “*”, all the programs marked with “*” will be re-multiplexed.

8.3.2 TS ID

Here user can configure and check the ID of TS stream.

TS ID: To configure and check the ID of TS stream. (Attention: The displayed TS ID is in accordance with ASI input or TS/IP input)

8.3.3 Output Bit Rate

Here user can configure the total bit rate of output TS stream.

Output Bit Rate: To configure the total bit rate of output TS stream.

8.3.4 MUX

Here user can submit the changed parameters for re-multiplexing function.

Remux: To submit the changed parameters for re-multiplexing. If there are some parameters or programs changing while the re-multiplexing function is running, user can re-submit these changes to make them valid.

8.3.5 MUX Source

Here user can configure the source of re-multiplexing function.

Remux Source: To configure the source of re-multiplexing function. User can select between ASI and TS/IP.

8.5 Output Setup

Here user can configure the output source. It includes 1 submenu. Menu format is shown as below:

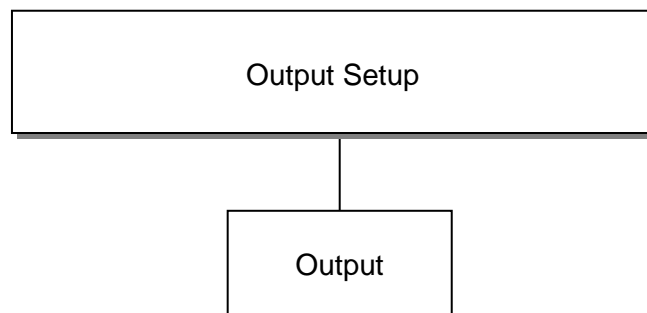

Output Source: To configure the source of output TS, user can select among Encode, Remux, ASI Input and TS/IP input.

8.6 System Setup

Here user can configure system parameters of this module. It includes 8 sub-menus: Unit Name, Version Info, Factory Setting, Machine Type, Force Upgrade and Watchdog.

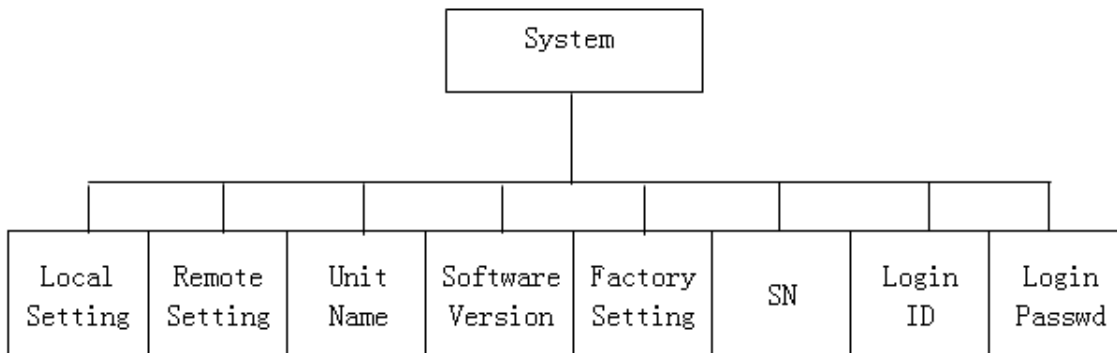

8.4.1 Local Setting: Configure the IP address for web control.

- (1) IP Address: Configure the local IP address.
- (2) Network Mask: Configure the network mask.
- (3) Gate Way: Configure the gateway address.
- (4) MAC Address: Check the MAC address.

8.4.2 Remote Setting: Configure the trap address for receiving warning in a PC.

8.4.3 Unit Name: Display the name of this module.

8.4.4 Software Version: Display the software version of this module.

8.4.5 Factory Setting: User can restore this module to factory setting.

8.4.6 SN: Display the serial number of this module.

8.4.7 Login ID: Configure the ID for login in the page of web control.

8.4.8 Login Passwd: Configure the Password for login in the page of web control.

9. Web Control

DMM-1520EC can be controlled by WEB. User can type IP address of DMM-1520EC in browser. It will show login pop-up. The default user name is “root” and password is “12345”. If you forget this username and password, you can use DMM-1000CU to check and change it.

9.1 Status Page

Here user can check status of input/output signal and TS/IP signal, as it shown in figure below.

- (1) Output status: Bitrate status of encoded TS and ASI output can be shown here.
- (2) Input status: Bitrate status of signal from TS/IP and ASI interfaces can be shown here.
- (3) Video Input Format: the format of SDI, HDMI and CVBS input signals will be shown here.
- (4) Gigabit Link Status: it will show whether Gigabit TS/IP port is locked.
- (5) Gigabit In Status: Show if the input TS/IP signal is locked.
- (6) Gigabit Out Status: Output status of gigabit can be shown here.
- (7) Refresh Interval: To set automatic webGUI refresh time interval.
- (8) Video Format Refresh: To manual refresh input video format detection.
- (9) Manual Refresh: To manual refresh the Status page.

DMM-1520EC

IP Address: 192.168.1.99

Status Encoder TS/IP Remux Output System	<div style="background-color: #f0f0f0; padding: 2px; text-align: center; font-weight: bold;">Output Status</div> <table style="width: 100%; border-collapse: collapse;"> <tr> <td style="width: 15%; background-color: #2e8b57; color: white; padding: 2px;">Encoder</td> <td style="padding: 2px;">Valid Bit Rate (Mb/s) <input style="width: 150px;" type="text" value="02.917760"/></td> <td style="padding: 2px;">Total Bit Rate (Mb/s) <input style="width: 150px;" type="text" value="05.000800"/></td> </tr> <tr> <td style="background-color: #2e8b57; color: white; padding: 2px;">Output</td> <td style="padding: 2px;">Valid Bit Rate (Mb/s) <input style="width: 150px;" type="text" value="02.927248"/></td> <td style="padding: 2px;">Total Bit Rate (Mb/s) <input style="width: 150px;" type="text" value="05.500952"/></td> </tr> <tr> <td colspan="3" style="padding: 2px;">Service Name <input style="width: 100%;" type="text" value="1520EC"/></td> </tr> </table> <div style="background-color: #f0f0f0; padding: 2px; text-align: center; font-weight: bold;">Input Status</div> <table style="width: 100%; border-collapse: collapse;"> <tr> <td style="width: 15%; background-color: #d9534f; color: white; padding: 2px;">ASI</td> <td style="padding: 2px;">Valid Bit Rate (Mb/s) <input style="width: 150px;" type="text" value="00.000000"/></td> <td style="padding: 2px;">Total Bit Rate (Mb/s) <input style="width: 150px;" type="text" value="00.000000"/></td> </tr> <tr> <td style="background-color: #d9534f; color: white; padding: 2px;">TS/IP</td> <td style="padding: 2px;">Valid Bit Rate (Mb/s) <input style="width: 150px;" type="text" value="00.000000"/></td> <td style="padding: 2px;">Total Bit Rate (Mb/s) <input style="width: 150px;" type="text" value="00.000000"/></td> </tr> </table> <div style="background-color: #f0f0f0; padding: 2px; text-align: center; font-weight: bold;">Video Input Format</div> <table style="width: 100%; border-collapse: collapse;"> <tr> <td style="width: 30%; padding: 2px;"><input checked="" type="radio"/> SDI Video Format</td> <td style="padding: 2px;"><input style="width: 100px;" type="text" value="720x576i 25"/></td> <td style="width: 30%; padding: 2px;"><input checked="" type="radio"/> HDMI Video Format</td> <td style="padding: 2px;"><input style="width: 100px;" type="text" value="Unknown Format"/></td> </tr> <tr> <td style="padding: 2px;"><input checked="" type="radio"/> CVBS Video Format</td> <td style="padding: 2px;"><input style="width: 100px;" type="text" value="Unknown Format"/></td> <td colspan="2"></td> </tr> </table> <div style="background-color: #f0f0f0; padding: 2px; text-align: center; font-weight: bold;">Gigabit Link Status</div> <table style="width: 100%; border-collapse: collapse;"> <tr> <td style="width: 30%; padding: 2px;"><input checked="" type="radio"/> Link Status</td> <td style="padding: 2px;">Linked 1000M</td> </tr> </table> <div style="background-color: #f0f0f0; padding: 2px; text-align: center; font-weight: bold;">Gigabit In Status</div> <table style="width: 100%; border-collapse: collapse;"> <tr> <td style="padding: 2px;">Gigabit In Status</td> <td style="padding: 2px;">Unlock</td> </tr> </table> <div style="background-color: #f0f0f0; padding: 2px; text-align: center; font-weight: bold;">Gigabit Out Status</div> <table style="width: 100%; border-collapse: collapse;"> <tr> <td style="padding: 2px;">UDP (Packets/s)</td> <td style="padding: 2px;">522</td> <td style="padding: 2px;">Column FEC (Pkts/s)</td> <td style="padding: 2px;">0</td> </tr> <tr> <td style="padding: 2px;">Row FEC (Pkts/s)</td> <td style="padding: 2px;">0</td> <td colspan="2"></td> </tr> </table> <div style="background-color: #f0f0f0; padding: 2px; text-align: center; font-weight: bold;">Refresh Interval</div> <table style="width: 100%; border-collapse: collapse;"> <tr> <td style="padding: 2px;">Interval</td> <td style="padding: 2px;"><input style="width: 50px;" type="text" value="20 seconds"/></td> <td style="padding: 2px; text-align: center;"><input type="button" value="Video Format Refresh"/></td> <td style="padding: 2px; text-align: center;"><input type="button" value="Manual Refresh"/></td> </tr> </table>	Encoder	Valid Bit Rate (Mb/s) <input style="width: 150px;" type="text" value="02.917760"/>	Total Bit Rate (Mb/s) <input style="width: 150px;" type="text" value="05.000800"/>	Output	Valid Bit Rate (Mb/s) <input style="width: 150px;" type="text" value="02.927248"/>	Total Bit Rate (Mb/s) <input style="width: 150px;" type="text" value="05.500952"/>	Service Name <input style="width: 100%;" type="text" value="1520EC"/>			ASI	Valid Bit Rate (Mb/s) <input style="width: 150px;" type="text" value="00.000000"/>	Total Bit Rate (Mb/s) <input style="width: 150px;" type="text" value="00.000000"/>	TS/IP	Valid Bit Rate (Mb/s) <input style="width: 150px;" type="text" value="00.000000"/>	Total Bit Rate (Mb/s) <input style="width: 150px;" type="text" value="00.000000"/>	<input checked="" type="radio"/> SDI Video Format	<input style="width: 100px;" type="text" value="720x576i 25"/>	<input checked="" type="radio"/> HDMI Video Format	<input style="width: 100px;" type="text" value="Unknown Format"/>	<input checked="" type="radio"/> CVBS Video Format	<input style="width: 100px;" type="text" value="Unknown Format"/>			<input checked="" type="radio"/> Link Status	Linked 1000M	Gigabit In Status	Unlock	UDP (Packets/s)	522	Column FEC (Pkts/s)	0	Row FEC (Pkts/s)	0			Interval	<input style="width: 50px;" type="text" value="20 seconds"/>	<input type="button" value="Video Format Refresh"/>	<input type="button" value="Manual Refresh"/>
Encoder	Valid Bit Rate (Mb/s) <input style="width: 150px;" type="text" value="02.917760"/>	Total Bit Rate (Mb/s) <input style="width: 150px;" type="text" value="05.000800"/>																																						
Output	Valid Bit Rate (Mb/s) <input style="width: 150px;" type="text" value="02.927248"/>	Total Bit Rate (Mb/s) <input style="width: 150px;" type="text" value="05.500952"/>																																						
Service Name <input style="width: 100%;" type="text" value="1520EC"/>																																								
ASI	Valid Bit Rate (Mb/s) <input style="width: 150px;" type="text" value="00.000000"/>	Total Bit Rate (Mb/s) <input style="width: 150px;" type="text" value="00.000000"/>																																						
TS/IP	Valid Bit Rate (Mb/s) <input style="width: 150px;" type="text" value="00.000000"/>	Total Bit Rate (Mb/s) <input style="width: 150px;" type="text" value="00.000000"/>																																						
<input checked="" type="radio"/> SDI Video Format	<input style="width: 100px;" type="text" value="720x576i 25"/>	<input checked="" type="radio"/> HDMI Video Format	<input style="width: 100px;" type="text" value="Unknown Format"/>																																					
<input checked="" type="radio"/> CVBS Video Format	<input style="width: 100px;" type="text" value="Unknown Format"/>																																							
<input checked="" type="radio"/> Link Status	Linked 1000M																																							
Gigabit In Status	Unlock																																							
UDP (Packets/s)	522	Column FEC (Pkts/s)	0																																					
Row FEC (Pkts/s)	0																																							
Interval	<input style="width: 50px;" type="text" value="20 seconds"/>	<input type="button" value="Video Format Refresh"/>	<input type="button" value="Manual Refresh"/>																																					

9.2 Encoder Page

Here user can configure and check parameters of encoder. User can click the button “Apply” or “Cancel” to submit or undo the new configuration, as it shown in figure below.

- (1) Encoder: Configure the bitrate which encoded TS is supposed to be.
- (2) Video Settings: Configure those parameters for video encoding (Video format and Aspect Ratio should be as same as the input video signal).
- (3) Audio Settings: Configure those parameters for audio encoding (Audio format should be as same as the input audio signal).

(4) Advanced Settings: Configure and check parameters of encoded TS, such as PID number. User can also configure parameters for changing the video scale.

Here's the menu of DMM-1520EC-X0 models:

DMM-1520EC

IP Address: 192.168.1.99

[Status](#)

[Encoder](#)

[TS/IP](#)

[Remux](#)

[Output](#)

[System](#)

Encoder

Encoder Bit Rate (kb/s)

Video Settings

Video Input Source	<input type="text" value="SDI"/>	Video Rate Ctl	<input type="text" value="CBR"/>
Input Format Adaptive	<input type="text" value="OFF"/>	Video Format	<input type="text" value="720x576i 25"/>
Video Bit Rate (kb/s)	<input type="text" value="2500"/>	Aspect Ratio	<input type="text" value="4:3"/>

Audio Settings

Audio1 Input Source	<input type="text" value="SDI"/>	Audio1 Channel Mode	<input type="text" value="Stereo"/>
Audio1 SDI EMB	<input type="text" value="EMB1"/>	Audio1 Level	<input type="text" value="0 dB"/>
Audio1 Format	<input type="text" value="MPEG1 Layer2"/>	Audio1 Bit Rate	<input type="text" value="256kbps"/>

Advanced Settings

Output Video PID	<input type="text" value="4010"/>	Output Audio1 PID	<input type="text" value="4011"/>
Output Service ID	<input type="text" value="701"/>	Output PMT PID	<input type="text" value="1001"/>
Output PCR PID	<input type="text" value="4012"/>	Output Service Name	<input type="text" value="1520EC"/>
Service Provider Name	<input type="text" value="DiviCom Customer"/>	Audio PTS Offset	<input type="text" value="100"/>
Scale	<input type="text" value="Disable"/>	Scale Horizontal	<input type="text" value="720"/>
Scale Vertical	<input type="text" value="576"/>		

Here's the menu of DMM-1520EC-X2 models:

DMM-1520EC

IP Address: 192.168.1.99

Status Encoder TS/IP Remux Output System	Encoder
	Encoder Bit Rate (kb/s) <input type="text" value="5000"/>
	Video Settings
	Video Input Source <input type="text" value="SDI"/> Video Rate Ctl <input type="text" value="CBR"/>
	Input Format Adaptive <input type="text" value="OFF"/> Video Format <input type="text" value="720x576i 25"/>
	Video Bit Rate (kb/s) <input type="text" value="2500"/> Aspect Ratio <input type="text" value="4:3"/>
	Audio Settings
	Audio1 Input Source <input type="text" value="HDMI"/> Audio1 Channel Mode <input type="text" value="Stereo"/>
	Audio1 SDI EMB <input type="text" value="EMB1"/> Audio1 Level <input type="text" value="+3 dB"/>
	Audio1 Format <input type="text" value="AAC LC"/> Audio1 Bit Rate <input type="text" value="128"/>
	Audio2 Input Source <input type="text" value="SDI"/> Audio2 Channel Mode <input type="text" value="Stereo"/>
	Audio2 SDI EMB <input type="text" value="EMB1"/> Audio2 Level <input type="text" value="0 dB"/>
	Audio2 Bit Rate <input type="text" value="192kbps"/>
	Advanced Settings
	Output Video PID <input type="text" value="4113"/> Output Audio1 PID <input type="text" value="4352"/>
	Output Audio2 Switch <input type="text" value="OFF"/> Output Audio2 PID <input type="text" value="4360"/>
	Output Service ID <input type="text" value="768"/> Output PMT PID <input type="text" value="4369"/>
	Output PCR PID <input type="text" value="4097"/> Output Service Name <input type="text" value="5202EC"/>
	Service Provider Name <input type="text" value="DiviCom Customer"/> Audio PTS Offset <input type="text" value="100"/>
	Scale <input type="text" value="Enable"/> Scale Horizontal <input type="text" value="360"/>
	Scale Vertical <input type="text" value="288"/>
	<input type="button" value="Apply"/> <input type="button" value="Cancel"/>

9.3 TS over IP Page

9.3.1 Gigabit In

Here user can check and configure parameters for receiving TS from IP port. User can click the button "Apply" or "Cancel" to submit or undo the new configuration, as it shown in figure below.

(1) Gigabit In: Configure Uni/Multicast IP address, port number and other parameters for receiving TS

from IP port.

(2) Gigabit In Status: Check if input TS from IP port is being locked.

DMM-1520EC
IP Address: 192.168.1.99

Status Encoder TS/IP Remux Output System	Gigabit In Gigabit Out Local Settings				
	Gigabit In				
	Uni/Multi Address	<input type="text" value="239"/>	<input type="text" value="100"/>	<input type="text" value="237"/>	<input type="text" value="1"/>
	Uni/Multi UDP Port	<input type="text" value="3000"/>			
	Column FEC UDP Port	<input type="text" value="1236"/>			
	Row FEC UDP Port	<input type="text" value="1238"/>			
	TS Clock Recovery	<input type="text" value="Auto"/>			
	Gigabit In Status				
	Gigabit In Status	Unlock			
	<input type="button" value="Apply"/> <input type="button" value="Cancel"/>				

9.3.2 Gigabit Out

Here user can check and configure parameters for outputting TS via IP port. User can click the button "Apply" or "Cancel" to submit or undo the new configuration, as it shown in figure below.

(1) Gigabit Out: Configure Uni/Multicast IP address, port number and other parameters for outputting TS via IP port.

(2) Gigabit Out Status: Check output status of TS over IP.

DMM-1520EC
 IP Address: 192.168.1.99

Status Encoder TS/IP Remux Output System	Gigabit In Gigabit Out Local Settings	
	Gigabit Out	
	Gigabit Out Switch	<input type="text" value="Enable"/>
	Protocol	<input type="text" value="UDP"/>
	TS Pkts Per UDP	<input type="text" value="7"/>
	Time To Live	<input type="text" value="255"/>
	Type of Service	<input type="text" value="Min Delay"/>
	Uni/Multi Address	<input type="text" value="239"/> <input type="text" value="99"/> <input type="text" value="100"/> <input type="text" value="1"/>
	Uni/Multi UDP Port	<input type="text" value="1234"/>
	Gigabit Out Status	
UDP (Packets/s)	522	
Column FEC (Pkts/s)	0	
Row FEC (Pkts/s)	0	
<input type="button" value="Apply"/> <input type="button" value="Cancel"/>		

9.3.3 Local Setting

Here user can check and configure parameters of TS/IP board. User can click the button “Apply” or “Cancel” to submit or undo the new configuration, as it shown in figure below.

DMM-1520EC

IP Address: 192.168.1.99

Status Encoder TS/IP Remux Output System	Gigabit In Gigabit Out Local Settings	
	Gigabit Local Settings	
	Gigabit Address	<input type="text" value="172"/> <input type="text" value="19"/> <input type="text" value="4"/> <input type="text" value="7"/>
	Gigabit Subnet Mask	<input type="text" value="255"/> <input type="text" value="255"/> <input type="text" value="255"/> <input type="text" value="224"/>
	Gigabit MAC Address	00:06:f4:31:3c:1e
	Gateway IP Address	<input type="text" value="172"/> <input type="text" value="19"/> <input type="text" value="4"/> <input type="text" value="1"/>
	Gateway MAC Address	<input type="text" value="ff"/> : <input type="text" value="ff"/> : <input type="text" value="ff"/> : <input type="text" value="ff"/> : <input type="text" value="ff"/> : <input type="text" value="ff"/>
	Gigabit Link Status	
	Link Status	Linked 1000M
	<input type="button" value="Apply"/> <input type="button" value="Cancel"/>	

9.4 Output Page

User can choose the source for ASI output among Encoder, MUX, ASI, and TS/IP Input. User can click the button “Apply” or “Cancel” to submit or undo the new configuration, as it shown in figure below.

DMM-1520EC

IP Address: 192.168.1.99

Status Encoder TS/IP Remux Output System	Output	
	Output Source	<input type="text" value="Remux"/> <ul style="list-style-type: none"> Remux Encoder Remux ASI Input TS/IP Input
	<input type="button" value="Apply"/> <input type="button" value="Cancel"/>	

9.5 Mux Page

User can check and configure parameters of re-multiplex function. User can select programs from ASI or TS/IP, then re-multiplex with the program from encoder into a new TS stream. User can also assign the TS ID and the bitrate for re-multiplexed TS. User can click the button “Apply” or “Cancel” to submit or undo the new configuration, as it shown in figure below.

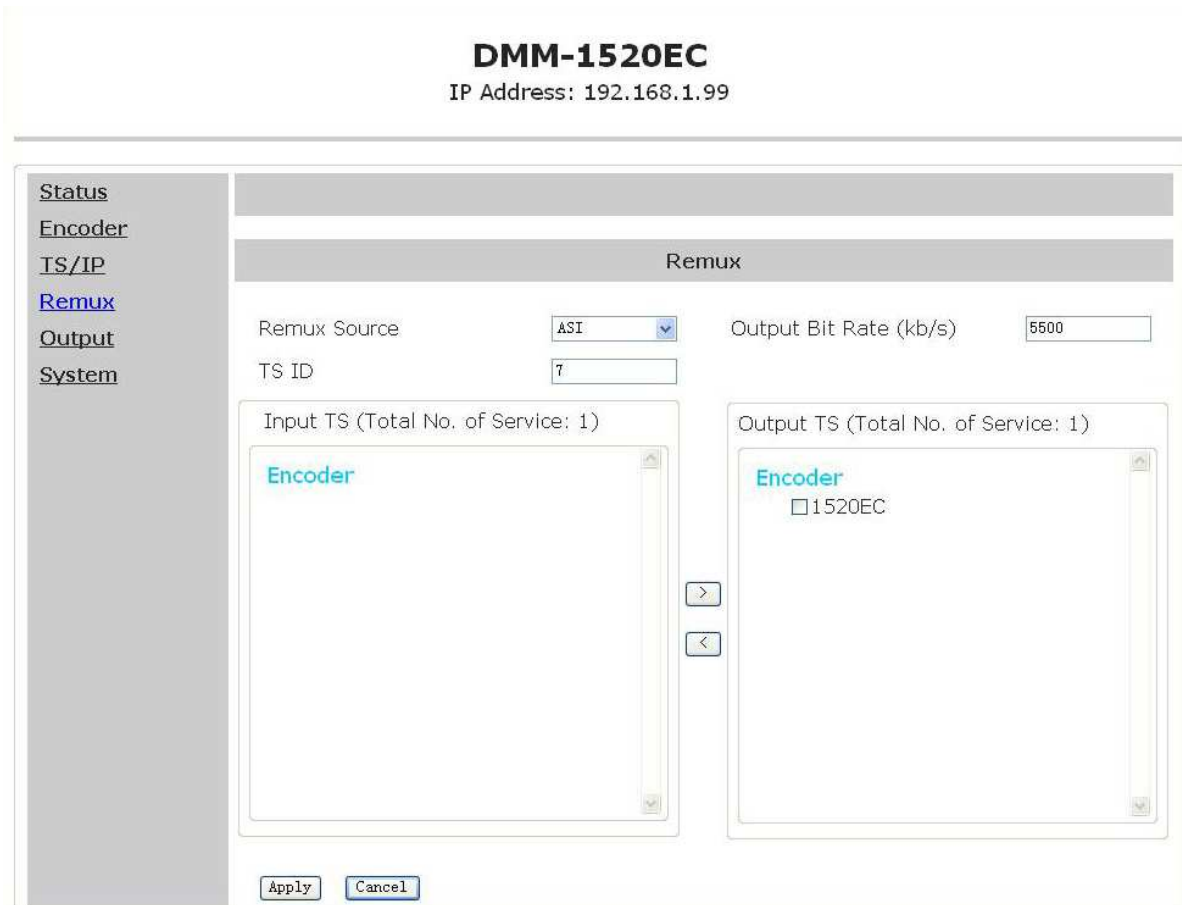

9.6 System Page

9.6.1 Device

Here user can check and configure parameters of this device. User can click the button “Apply” or “Cancel” to submit or undo the new configuration, as it shown in figure below.

- (1) Device Information: Check the name and the serial number of this device. User can also assign device name at will.
- (2) Login: User can set his own username and password for webGUI access.
- (3) Factory Default: User can click the button “Factory Default” to restore this module to factory default setting.
- (4) Device Reboot: User can click the button “Device Reboot” to restart this module.

DMM-1520EC

IP Address: 192.168.1.99

Status Encoder TS/IP Remux Output System	Device Version Network Preset			
	Device Information			
	Product Name	<input type="text" value="DMM-1520EC"/>		
	Serial Number	<input type="text" value="LA9B022270057"/>		
	Login			
	Login ID	<input type="text"/>		
	Login Password	<input type="text"/>		
	<input type="button" value="Apply"/> <input type="button" value="Cancel"/>		<input type="button" value="Factory Default"/> <input type="button" value="Device Reboot"/>	

9.6.2 Version

Here user can check various detail versions of the firmware.

DMM-1520EC

IP Address: 192.168.1.99

Status Encoder TS/IP Remux Output System	Device Version Network Preset			
	Version			
	Software Version	1522EC000A		
	FPGA Version	0B		
	Gigabit Version	0508		
	Encoder Version	01		
	Web Version	012A		

9.6.3 Network

Here user can check and configure network for remote control and other parameters. User can click the button "Apply" or "Cancel" to submit or undo the new configuration, as it shown in figure below.

- (1) Local Settings: Check and configure network parameters for web control.
- (2) Remote Setting: Configure the trap IP address for receiving warning information by a PC.

DMM-1520EC
IP Address: 192.168.1.99

Status	Device	Version	Network	Preset	
Encoder	Network				
TS/IP	Local Settings				
Remux	IP Address	192	168	1	99
Output	Subnet Mask	255	255	255	0
System	Gateway	10	10	70	1
	MAC Address	00:06:f4:31:3c:1d			
	Remote Setting				
	Trap IP Address	10	10	90	25
	<input type="button" value="Apply"/> <input type="button" value="Cancel"/>				

9.6.4 Preset

Here user can download the configuration of device to PC, or upload configuration file from a PC to the device.

- (1) Download: Check “Download” button and select a location to save configuration file of this Device to a PC. The configuration file will be a “xxx.pre” file.
- (2) Upload: Click “Browse...” button to choose a configuration file on PC. Then click “Upload” button to load configuration to the device.



DMM-1520EC

IP Address: 192.168.1.99

Status Encoder TS/IP Remux Output System	Device Version Network Preset			
	Preset			
	Download	<input type="button" value="Download"/>		
	Upload	<input type="text"/>	<input type="button" value="浏览..."/>	<input type="button" value="Upload"/>